

## Technical data

### S.CF 24 G – 45' EURO

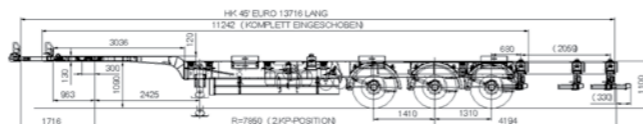

Permissible / technical axle load	24,000 kg	27,000 kg
Permissible / technical trailer load	11,000 kg	15,000 kg
Permissible / technical total weight	35,000 kg	39,000 kg
Unladen weight basic configuration		5,600 kg
Maximum container weight, 20' centrally mounted		30,000 kg
Fifth-wheel height, unladen		1,100 mm
Fifth-wheel height, laden		1,075 mm
Low bed loading height, unladen		1,100 mm
Low bed loading height, laden		1,075 mm
Crank height		120 mm
Body height at front frame neck incl. pick-up plate (neck height)		130 mm
Front beam		2,040 mm
Wheelbase: 2nd king pin position		7,850 mm
Wheelbase: 1st king pin position (for three-axle semi-trailer tractors)		8,150 mm
Front axle spacing		1,410 mm
Rear axle spacing		1,310 mm
20' flush with rear		Standard
20' centrally mounted		Standard
2 x 20'		Standard
30'		Standard
40' with tunnel		Standard
40' without tunnel		Option
45' EU container with long tunnel and sloping edges		Standard
45' with short tunnel*		Standard
45' without tunnel		Option

\* Certificate of exemption as per § 70 Road Traffic Act required. We reserve the right to make technical changes.

## One-Stop Solution

### Premium Services from Schmitz Cargobull



**SCHMITZ**  
**CARGOBULL**

The Trailer Company.



## Container Chassis S.CF 45' EURO

The Universal Talent for Containers from 20' to 45'

### Benefits at a glance:

- Flexible: prepared for 20' to 45' containers with or without tunnel
- Practical: pneumatic rear extension, mechanical front extension
- Optional: locking systems for 40' and 45' containers without tunnel
- Seaworthy: 2 pairs of ferry lashings
- Sophisticated: 130 mm frame neck height for a max. 4,000 mm total height

S.CF-EURO-FLY-DEIGB-10586-3522 We reserve the right to make changes. Some illustrations show special equipment.

\* Option



Patented **MULTI LOCK** on the front beam in locking position for tunnel container with sloping corners.

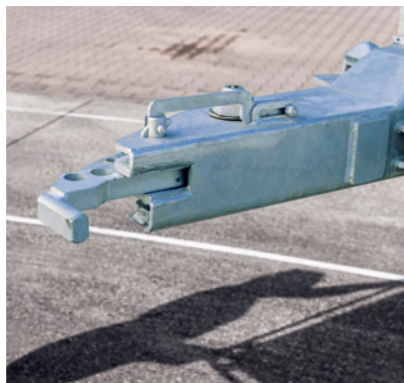

**MULTI LOCK** adjusted to tunnel containers with straight corners.

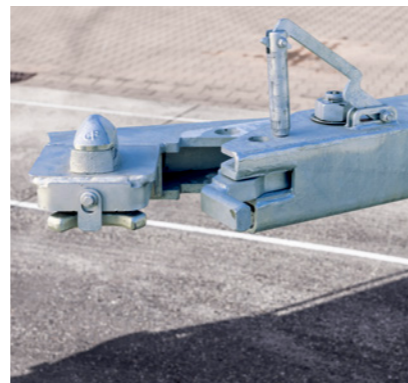

With folded-out **TWIST LOCK** for containers without tunnel and positive-guided twist lock on the front beam.

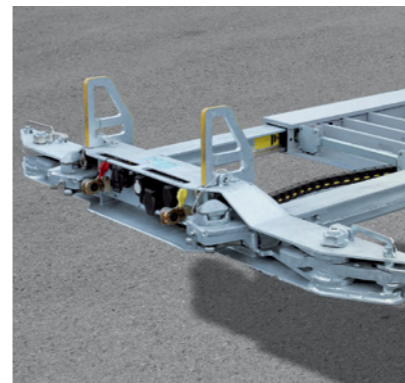

The **front extension** for 45' containers is spring-mounted on roller bearings, providing simple, safe and rapid handling.



The **rear extension** extends pneumatically to the selected container position. For 45' containers - pull-out underride guard.



**Manual locking** for pneumatic rear extension.

## Container Chassis S.CF 45' EURO

### Your Universal Frame for All Sea Containers up to 45'

The S.CF EURO 45' semi-trailer container chassis gives you flexibility. The right combination of safety, time efficiency and economy - from the 20' standard container to the 45' EU container with long tunnel and sloping edges. The **MULTI LOCK®** secures the container on the front extension, the **KLAPP LOCK** attaches the front container for 2 x 20' loading and the **STEP LOCK®** secures standard containers with and without tunnel on the rear extension.

S.CF EURO standard equipment includes an extendable underride guard.

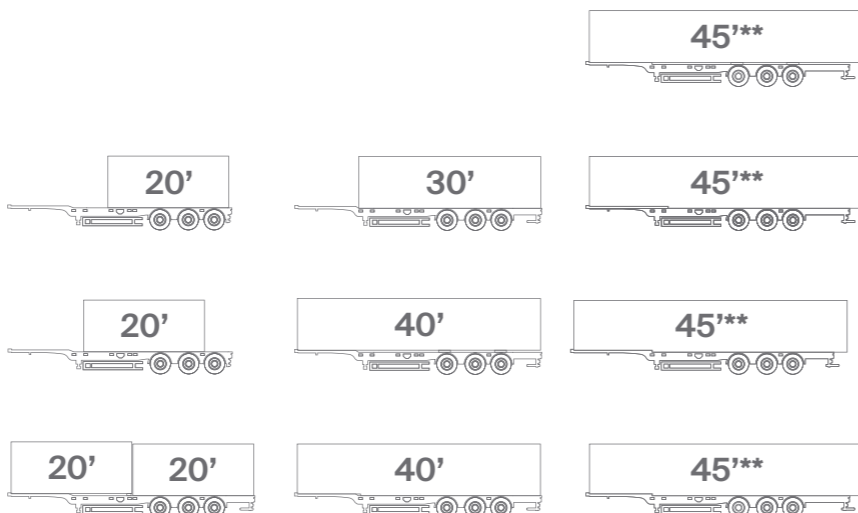

**Container layout**

\*\* Certificate of exemption as per § 70 Road Traffic Act required.

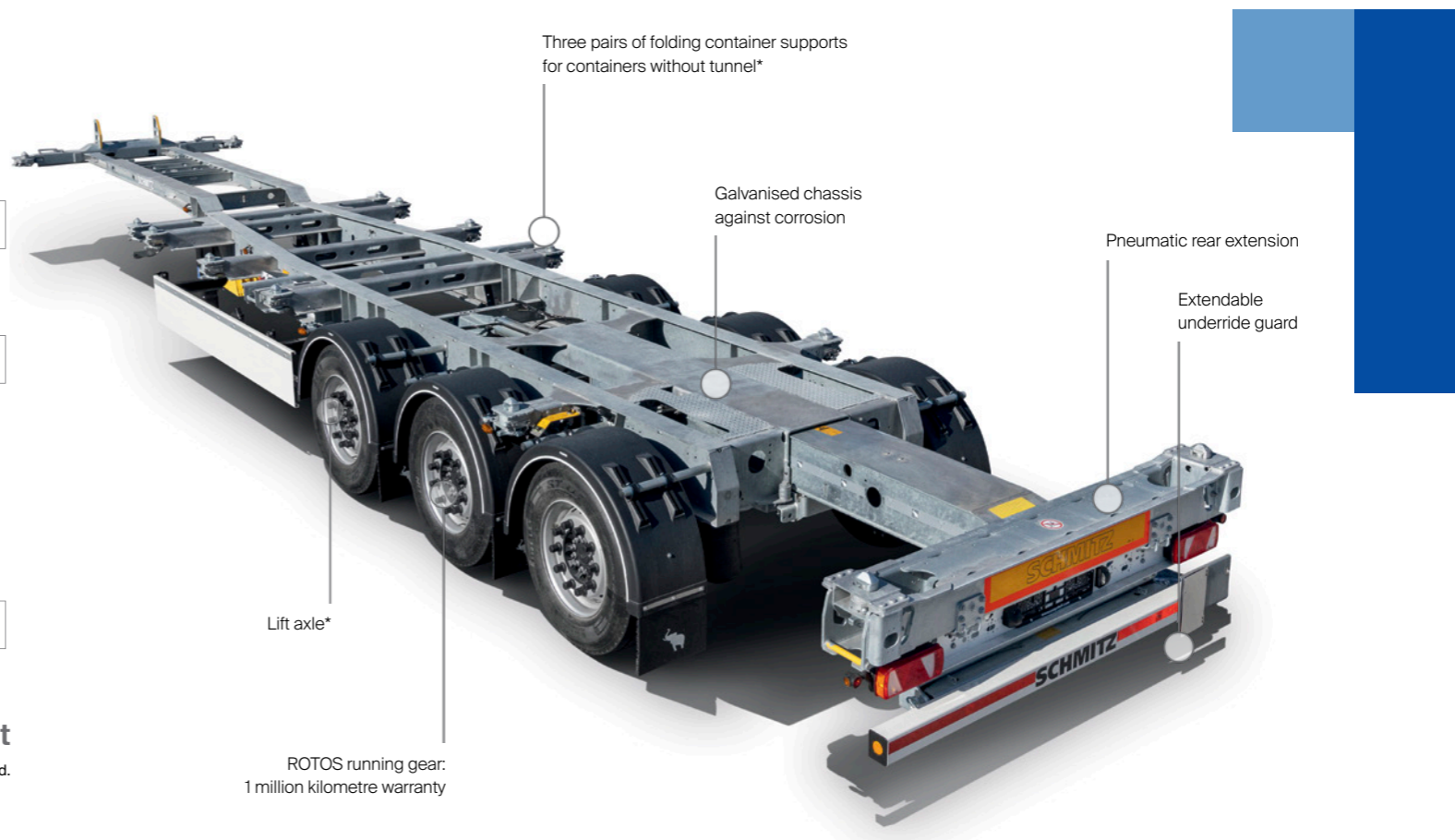

Two **STEP LOCKS®** on the rear extension allow you to adjust your semitrailer/container chassis in a matter of moments.



With 2x20' loads the two **KLAPPLOCKS** serve to lock the rear end of the front container.



Three pairs of folding container supports for containers without tunnel\*.



Long service life: Schmitz Cargobull container chassis are constructed using **high-strength steel profiles** and systematically protected against corrosion.



The container trailer chassis is equipped with **ferry lashings** as standard for use with ferry transport.



The **lift axle\*** as a starting aid extends the wheelbase and, thus, increases the pressure on the drive axle.

Illustrations may include optional equipment. \* Optional.